

TKA 38.5 KS

BISON PALFINGER



IMPRESSIVE IN ANY DUTY



TELESCOPIC JIB

The special feature of the TKA 38.5 is the double-telescopic jib which can be angled upwards in any position of the main boom. Naturally, the TKA 38.5 KS also incorporates all the other advantages of the BISON KS series – counter slewing system, very short and compact design, turning within the width of the vehicle, automated outriggers, automatic setup levelling and lots more. With a total weight of 18 t the platform achieves an enormous lateral outreach of 27 m, attaining a working range which meets the highest requirements.

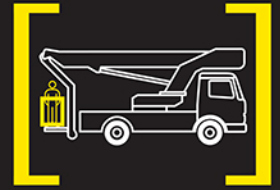



Counter slewing system (KS)

Slewing within the width of the vehicle – this figure is only achievable with the patented counter slewing system. Preventing the need for blocking off opposite carriageways and problem-free deployment in the tightest spaces illustrate the unmatched advantages of the KS series.



Max. horizontal outreach

BISON aerial work platforms offer the greatest horizontal outreaches! This is achieved by perfect lightweight construction and premium material quality as well as by the design of our engineers.



Compact overall length thanks counter slewing system

Exceptionally manoeuvrable in all jobs – the counter slewing system minimises the vehicle length of a BISON KS aerial work platform because the space above the driver's cab can be optimally utilised.



Outrigger control from the working basket

All four outriggers can be controlled from the working basket with a clear view and maximum operating convenience.



Automated outriggers and setup levelling

Greatest-possible safety and protection of the unit on any terrain – thanks to the automated outriggers and automatic setup levelling all four stabilisers are extended at the same time and the stabilised position can be achieved easily.



Ultra-modern control technology

Greatest-possible working convenience and long service life – the high-performance and redundant safety programme control aligns the movements of the platform optimally in each and every situation.



Everything internally routed

All the energy hoses, chains, cables and telescopic cylinders are located inside the arm system and are therefore excellently protected against damage and the effects of the weather. Smooth surfaces and clear line direction characterise the external appearance.



HIGHEST RELIABILITY



Easy to operate

Full concentration on the actual work – that is the basis for successfully tackling any job! The platform is extremely easy to control from the basket by means of a sensitive electro-hydraulic proportional control system and a Danfoss control valve.



Hydraulic system

Speedy servicing of the high-quality hydraulic components is ensured thanks to their easy access and clear arrangement. All components are optimally protected against the environment and damage and are housed in closed installation spaces.



Telescopic arms

The hexagonal shape of the arm profiles and the inclined arrangement of the slide blocks mean that the telescopic arms secure self-centering and lateral play is reduced to a minimum. The noticeable advantage of this is the particularly high stability during deployment.



Stowage space and tool boxes

Generous and easily accessible stowage space for material and tools is perfectly integrated in the body.



Automatic cage boom arresting

The jib is released when the auxiliary drive is switched on and is automatically hydraulically locked as soon as the auxiliary drive is switched off. This means it is not necessary to follow a specific sequence of movements when putting the unit in and out of transport position.



Low-maintenance

Aerial work platforms from BISON PALFINGER are high quality and require little maintenance.



Paintwork

BISON aerial work platforms impress by virtue of their excellent paintwork quality which is unique on the market.



COMPACT DESIGN

TKA 38.5 KS working area

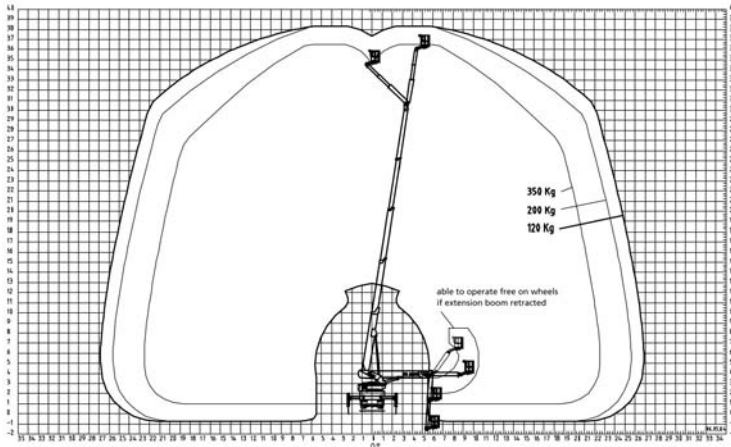

Bison TKA 38.5 KS	
Specification of basic unit	
Max. working height	38.5 m
Max. basket floor level	36.5 m
Max. horizontal working area / with basket load	27.0 m / 120 kg 22.5 m / 350 kg

Bison TKA 38.5 KS	
Moving free on wheels	
Working mode	
"moving free on wheels"	standard

Bison TKA 38.5 KS	
Workman basket	
Width x Length x Height	2.00 x 0.82 x 1.135 m
Slewing range of workman basket	2 x 45°
Max. basket load	350 kg
Engine start / stop in the workman basket	standard
Plastic cover over basket control desk	standard
230 V CEE adapter in the workman basket	standard
2 ancor rings for connecting safety harnesses	standard

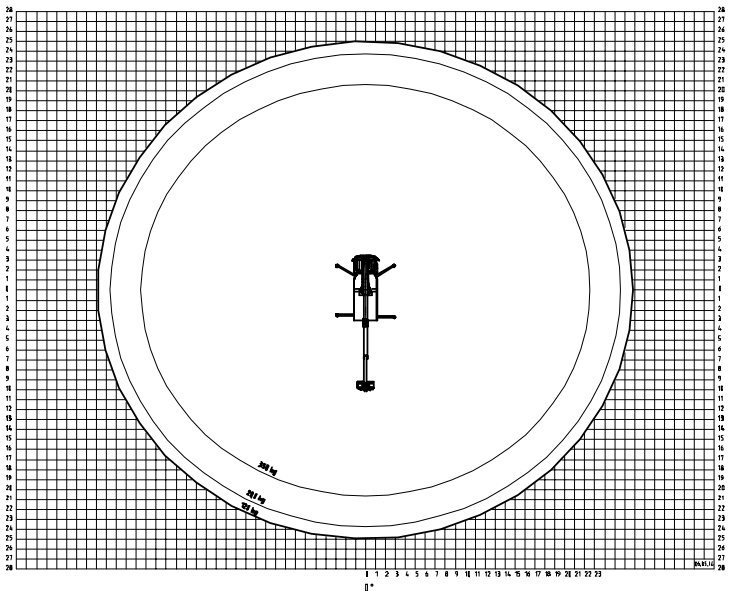

Bison TKA 38.5 KS	
Boom system	
Number of extendable sections in the main boom	4
Boom shape	hexagon
All cables, hoses and mecanical components incorporated well protected inside the boom system	standard
Hydraulic articulating boom, working range	150°
Number of extendable sections in the articulating boom	2
Automatic locking / releasing of articulating boom depending on p.t.o. position (engaged / disengaged)	standard
Automatic return to transport position	standard

AUTOMATIC SETUP LEVELLING

Bison TKA 38.5 KS	
Slewing system	
Design of slewing system	counter slewing system
Slewing within the vehicle width	standard
Slewing range	500°

Bison TKA 38.5 KS	
Stabilizers	
Working principle of stabilizers	variable
Min. stabilizer spread – all outriggers retracted	2.25 m
Stabilizer spread – one side extended, one side retracted	3.48 m
Max. stabilizer spread – both sides fully extended	4.70 m
Stabilizer controls at the workman basket	standard
Automatic stabilizing and automatic levelling	standard
LED on all 4 stabilizer legs	standard
4 support plates	standard

Bison TKA 38.5 KS	
Carrier vehicle and installation	
GVW class	18 to 19 t
Length in transport position	8.60 m*
Width in transport position	2.50 m*
Height in transport position	3.80 m*
High pressure filter	standard
Hydraulic oil tank with return line filter	standard

m* depending on carrier vehicle

Bison TKA 38.5 KS	
Manual and emergency controls	
Lockably integrated and well protected in the body	standard
Emergency hand pump	standard

TKA 38.5 KS transport delivery

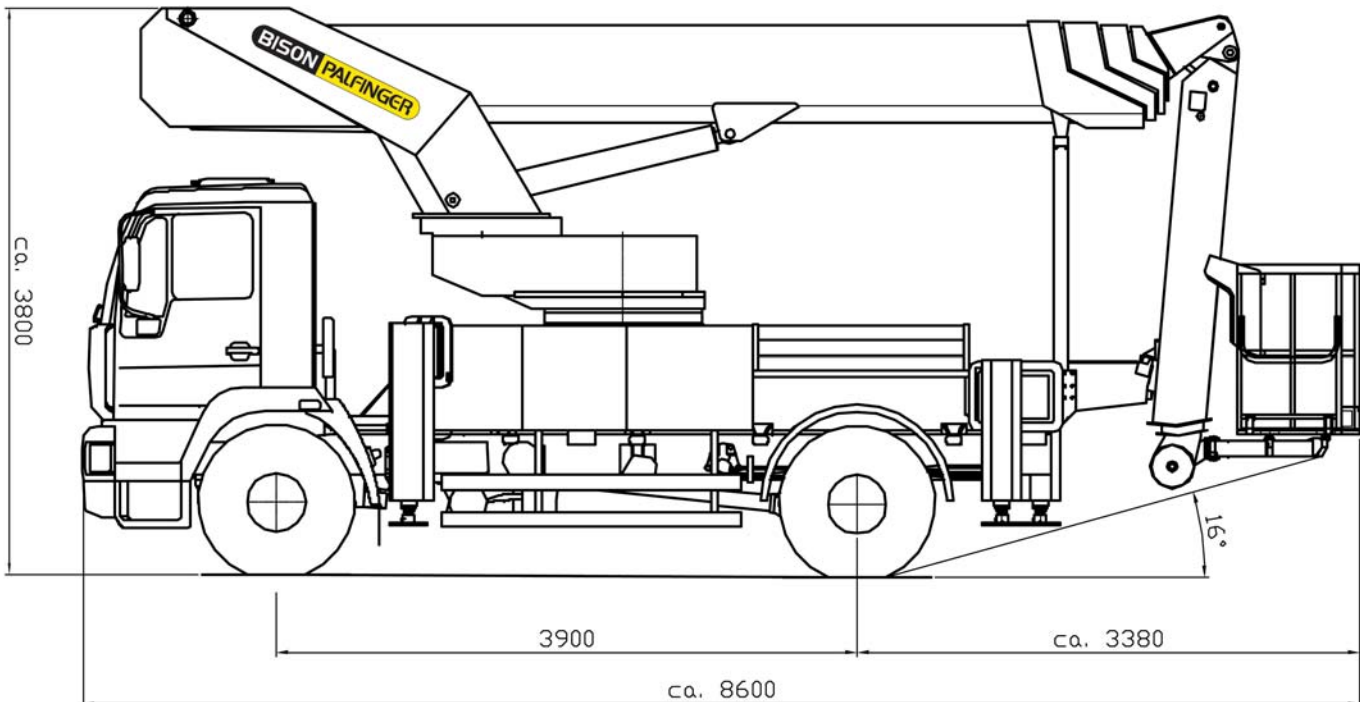

The equipment displayed is partly fitted with special equipment and therefore do not always correspond to the standard model. Country specific stipulations must be additionally adhered to.

PALFINGER

We reserve the right to change design and specification without prior notice.

KP-BITKA385KSM1+E, 06/05

www.palfinger.com